

超洁亮配件手册

Nano Coating Machine Parts manual

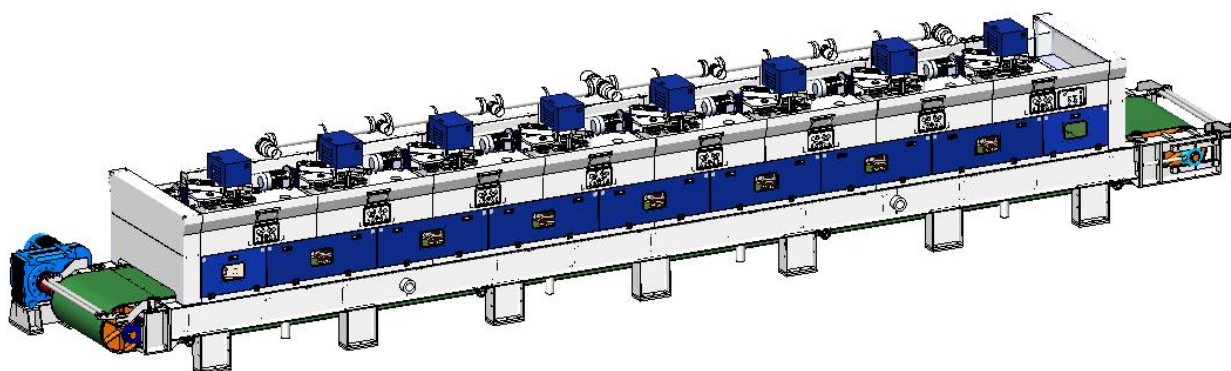

请妥善保管此手册以备查阅

佛山市巴赛尔机电有限公司

FoShan Basair Mechanical & Electrical Co.,

目 录

第 1 章 概述 Summary	1
1.1 性能参数 performance parameter	1
项目 item	1
参数 parameter	1
1000 型 8 头超洁亮 Model 1000 8-head Nano Coating Machine	1
电源电压 mains input	1
380 V / 50 Hz	1
装机功率 installed power	1
191 kW	1
气源压力 bleed pressure	1
≥0.6 MPa	1
外形尺寸 size	1
13100 (Length) x 3000 (Width) x 2000 (Height)	1
1.2 设备概述 Equipment Summary	1
1.3 使用机器的注意事项	2
第 2 章 组件图及明细表 Component drawings and specification	3
2 超洁亮整机及明细表 The specification of Nano coating machine	3
2.1 1000 型 8 头超洁亮机架组件及明细表 Model 1000 8-head Nano Coating Machine Components and specification	4
2.1.1 机架皮带限位轮组件及明细表 Frame belt limit wheel Components and specification	6
2.1.2 1000 型皮带托辊组件及明细表 Model 1000 machine Belt idler Components and specification	6
2.1.3 1000 机被动辊筒组件及明细表 Model 1000 machine Passive roller Components and specification	7
2.1.4 1000 机主动辊筒组件及明细表 Model 1000 Machine drive roller Components and specification	8
2.1.6 1000 机过渡辊棒组件(主动)明细表 Model 1000 Machine Transition roller Components (drive) specification	10
2.1.7 1000 型 8 头超洁亮导蜡槽组件及明细表 Model 1000 8-head Nano Coating Machine Wax guide tank Components and specification	11
2.1.8 超洁亮主传动组件及明细表 Nano coating machine Main drive components and specification	13
2.2 1000 型龙门架组件及明细表 Model 1000 machine portal frame components and specifications	14
2.2.1 主轴升降组件及明细表 Spindle lifting components and specification	15
2.2.2 升降气缸组件及明细表 Lifting cylinder components and specification	16
2.2.3 减速机组件及明细表 Reducer components and specification	17
2.2.4 聚电箱组件及明细表 Polyelectric box components and specification	18
2.2.5 小磨头组件及明细表 Small polishing head components and specification	19
2.2.6 1000 型升降限位组件及明细表 Model 1000 machine Lifting limit components and specification	19

2.3 1000 型 8 头超洁亮钣金组件及明细表 Model 1000 8-head Nano Coating Machine Sheet metal components and specification.....	20
2.3.1 1000 机前侧门组件及明细表 Model 1000 machine Front side door components and specification	22
2.3.2 1000 机前门组件及明细表 Model 1000 machine Front door components and specification	22
2.3.3 1000 机后侧门组件及明细表 Model 1000 machine Rear side door components and specification	23
2.3.4 1000 机后门组件及明细表 Model 1000 machine Backdoor components and specification.	24
2.3.5 1000 型 8 头超洁亮面板架组件及明细表 Model 1000 8-head Nano Coating Machine Panel rack components and specification.....	24
2.3.6 1000 型 8 头超洁亮挡板组件及明细表 Model 1000 8-head Nano Coating Machine Baffle components and specification.....	26
2.3.7 1000 型 8 头超洁亮线槽组件（右线）及明细表 Model 1000 8-head Nano Coating Machine Slot components (right line) and specification.....	26
2.4 1000 型 8 头超洁亮管道组件及明细表 Model 1000 8-head Nano Coating Machine Piping components and specification.....	27
2.4.1 1000 型 8 头超洁亮风管组件及明细表 Model 1000 8-head Nano Coating Machine flue pipe components and specification.....	28
2.4.2 1000 型 8 头超洁总气管组件及明细表 Model 1000 8-head Nano Coating Machine Total tracheal components and specification.....	30
2.4.3 1000 型 8 头超洁亮加蜡管道组件及明细表 Model 1000 8-head Nano Coating Machine Waxed pipe components and specification.....	31
表 1 磨头组件明细表 table1 polishing head Components and specification.....	4
表 2 超洁亮机架组件明细表 table2 Nano Coating Machine Components and specification.....	5
表 3 机架皮带限位轮组件明细表 table3 Frame belt limit wheel Components and specification	6
表 4 1000 型皮带托辊组件明细表 table4 Model 1000 machine Belt idler Components and specification	7
表 5 1000 机被动辊筒组件明细表 table5 Model 1000 machine Passive roller Components and specification	8
表 6 1000 机主动辊筒组件明细表表 table6 Model 1000 Machine drive roller Components and specification.....	9
表 7 1000 机过渡辊棒组件（被动）明细表 table7 Model 1000 Machine Transition roller Components (passive) and specification.....	10
表 8 1000 机过渡辊棒组件（主动）明细表 table8 Model 1000 Machine Transition roller Components (drive) specification	11
表 9 1000 型 8 头超洁亮导蜡槽组件明细表 table9 Model 1000 8-head Nano Coating Machine Wax guide tank Components and specification.....	12
表 10 被动调宽座组件明细表 table10 Nano coating machine Main drive components and specification	13
表 11 1000 型龙门架组件明细表 table11 Model 1000 portal frame components and specifications	14
表 12 主轴升降组件明细表 table12 Spindle lifting components and specification.....	16
表 13 升降气缸组件明细表 table13 Lifting cylinder components and specification.....	17
表 14 减速机组件明细表 table14 Reducer components and specification.....	17

表 15 聚电箱组件明细表 table15 Polyelectric box components and specification.....	18
表 16 小磨头组件明细表 table16 Small polishing head components and specification.....	19
表 17 1000 型升降限位组件明细表 table17 Model 1000 machine Lifting limit components and specification.....	20
表 18 1000 型 8 头超洁亮钣金组件明细表 table18 Model 1000 8-head Nano Coating Machine Sheet metal components and specification.....	21
表 19 1000 机前侧门组件明细表表 table19 Model 1200 machine Front side door components and specification.....	22
表 20 1000 机前门组件明细表 table20 Model 1000 machine Front door components and specification.....	23
表 21 1000 机后侧门组件明细表 table21 Model 1000 machine Rear side door components and specification.....	24
表 22 1000 机后门组件明细表 table22 Model 1000 machine Backdoor components and specification.....	24
表 23 1000 型 8 头超洁亮面板架组件明细表 table23 Model 1000 8-head Nano Coating Machine Panel rack components and specification.....	25
表 24 1000 型 8 头超洁亮挡板组件明细表 table24 Model 1000 8-head Nano Coating Machine Baffle components and specification.....	26
表 25 1000 型 8 头超洁亮线槽组件（右线）明细表 table25 Model 1000 8-head Nano Coating Machine Slot components (right line) and specification.....	27
表 26 1000 型 8 头超洁亮管道组件明细表 table26 Model 1000 8-head Nano Coating Machine Piping components and specification.....	28
表 27 1000 型 8 头超洁亮风管组件明细表 table27 Model 1000 8-head Nano Coating Machine flue pipe components and specification.....	29
表 28 1000 型 8 头超洁亮总气管组件明细表 table28 Model 1000 8-head Nano Coating Machine Total tracheal components and specification.....	30
表 29 1000 型 8 头超洁亮加蜡管道组件明细表 table29 Model 1000 8-head Nano Coating Machine Waxed pipe components and specification.....	31

第 1 章 概述 Summary

1.1 性能参数 performance parameter

项目 item	参数 parameter
	1000 型 8 头超洁亮 Model 1000 8-head Nano Coating Machine
电源电压 mains input	380 V / 50 Hz
装机功率 installed power	191 kW
气源压力 bleed pressure	≥ 0.6 MPa
外形尺寸 size	13100 (Length) x 3000 (Width) x 2000 (Height)

1.2 设备概述 Equipment Summary

设备功能描述：此系列固定款超洁亮用于对宽度 1000 以内的瓷质抛光砖进行抛光打蜡处理，能有效地提高产品的表面光泽度和防污能力，从而大大提高产品的使用质量。

设备特点描述：

- 1、磨头无需专门润滑，磨损小，结构简单稳定。
- 2、整机标准化程度高，操作简单，维护成本低。

Equipment function description: This series of fixed super clean and bright for the width of 1200 porcelain polished brick polishing waxing treatment, can effectively improve the product surface gloss and anti-fouling ability, so as to greatly improve the quality of the product.

Description of equipment characteristics:

- 1, grinding head without special lubrication, wear small, simple and stable structure.
2. The machine has high standardization, simple operation and low maintenance cost.

1.3 使用机器的注意事项

- ①、保证正常的电源电压
- ②、供气压不能低于额定气压 0.6Mpa
- ③、机器不使用时请关掉电源
- ④、勿随意更换或拆卸机器上的零件
- ⑤、维修保养时注意安全
- ⑥、机器工作请勿站在机器工作范围内以免被弄伤

1.3 Precautions for using the machine

- ①, ensure the normal power supply voltage
- ②, the air supply pressure should not be lower than rated air pressure 0.6Mpa
- ③, Please turn off the power when the machine is not in use
- ④, Do not replace or remove the parts on the machine at will
- ⑤, Pay attention to safety during maintenance
- ⑥, do not stand in the working range of the machine in order to avoid injury

第 2 章 组件图及明细表 Component drawings and specification

2 超洁亮整机及明细表 The specification of Nano coating machine



表1 磨头组件明细表 table1 polishing head Components and specification

序号 NO.	名称 Name	规格型号 Size	单位 Unit	数量 Qty
1	超洁亮机架组件 Nano coating machine Rack assembly	1000 型 8 头 Model 1000-8head	套 set	1
2	超洁亮龙门架组件 Nano coating machine Gantry assembly	1000 型 Model 1000	套 set	8
3	超洁亮钣金组件 Nano coating machine Sheet metal assembly	1000 型 8 头 Model 1000-8head	套 set	1
4	超洁亮管道组件 Nano coating machine Piping assembly	1000 型 8 头 Model 1000-8head	套 set	1

2.1 1000 型 8 头超洁亮机架组件及明细表 Model 1000 8-head Nano Coating Machine Components and specification

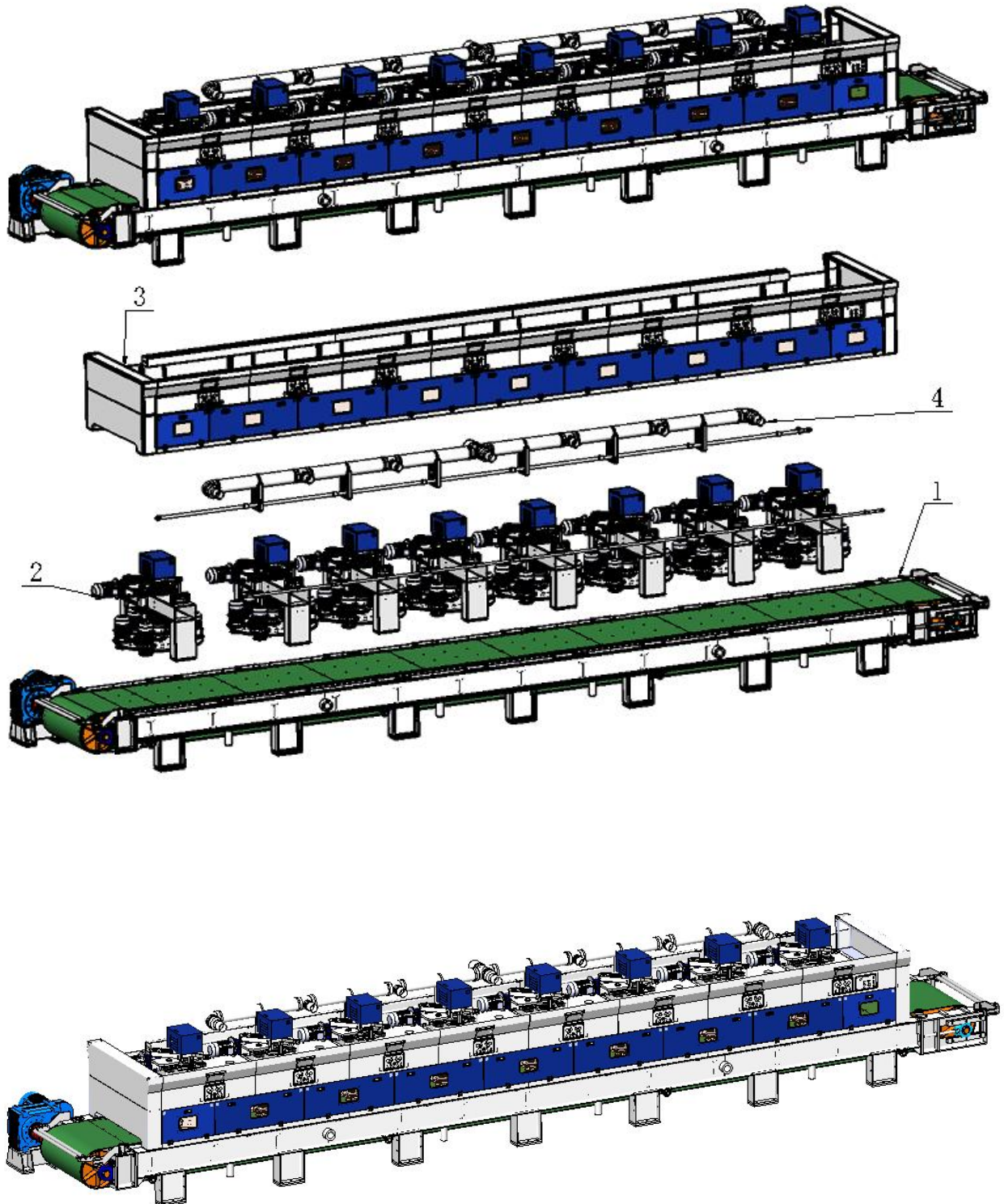

表2 超洁亮机架组件明细表 table2 Nano Coating Machine Components and specification

序号 NO.	名称 Name	规格型号 Size	单位 Unit	数量 Qty
1	超洁亮机架 Nano coating machine rack	1000 型 8 头 Model 1000-8head	件 pcs	1
2	超洁亮机脚调节板 Nano coating machine Foot adjusting plate	350x175x20	件 pcs	14
3	1000 机耐磨底板 Model 1000 AWear-resistant bottom plate A	1050x1278x5.5	件 pcs	8
4	1000 机耐磨底板 Model 1000 wear-resistant bottom plate B	1050x458x5.5	件 pcs	2
5	皮带 belt	26100x1100x9	条	1
6	机架皮带限位轮组件 Rack belt limit wheel assembly		套 set	4
7	1000 型皮带托辊组件 Model 1000 Belt roller assembly	1000 型 Model 1000	套 set	4
8	1000 机被动辊筒组件 Model 1000 Passive roller assembly	1000 型 Model 1000	套 set	1
9	1000 机主动辊筒组件 Model 1000 Driving roller assembly	1000 型 Model 1000	套 set	1
10	1000 机过渡辊棒组件 (被动) Model 1000 Transition roller assembly (passive)	1000 型 Model 1000	套 set	1
11	1000 机过渡辊棒组件 (主动) Model 1000 Transition roller assembly (active)	1000 型 Model 1000	套 set	1
12	1000 型 8 头超洁亮导蜡槽组件 Model 1000-8head Wax guide groove assembly	1000 型 8 头 Model 1000-8head	套 set	1
13	超洁亮主传动组件 Nano coating machine Main drive unit	F127-15kw	套 set	1

2.1.1 机架皮带限位轮组件及明细表 Frame belt limit wheel Components and specification

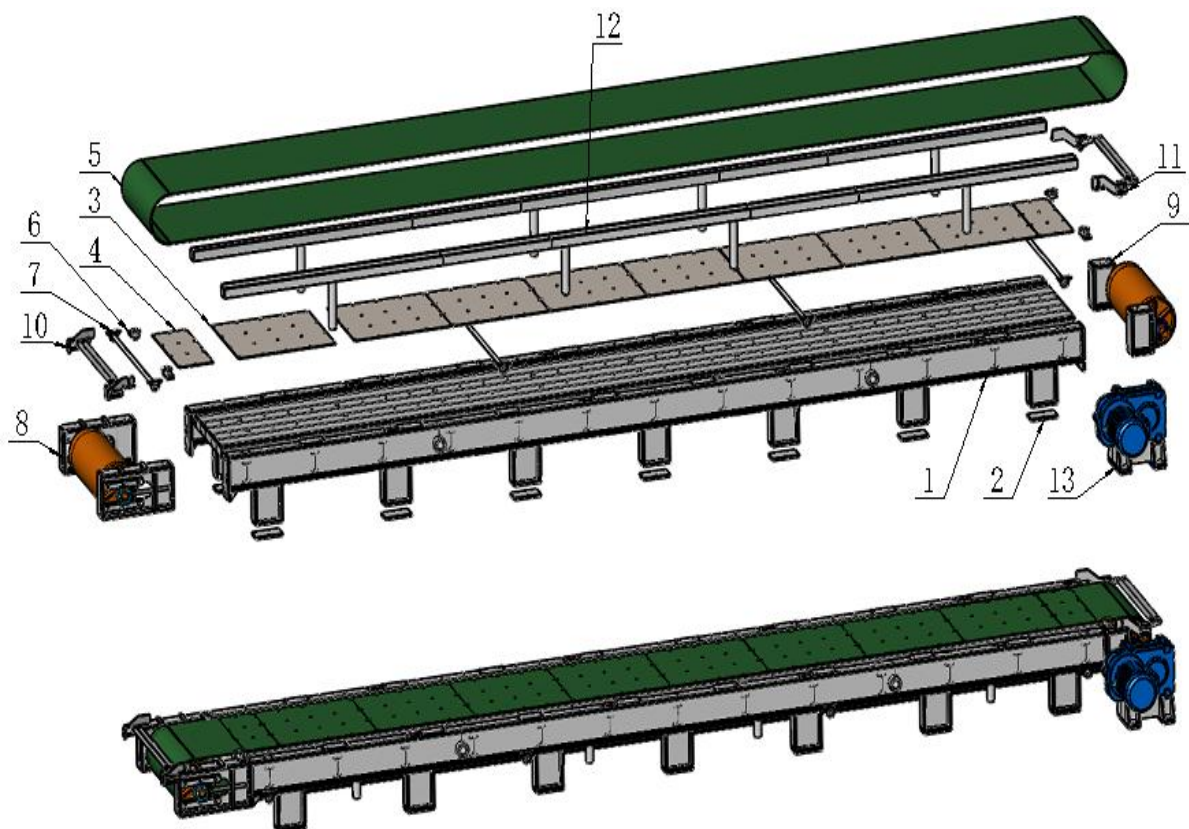

表3 机架皮带限位轮组件明细表 table3 Frame belt limit wheel Components and specification

序号 NO.	名称 Name	规格型号 Size	单位 Unit	数量 Qty
1	限位轮安装板 Limit wheel mounting plate	180x100x14	件 pcs	1
2	皮带限位轮轴 Belt limit axle	Ø40x80	条 pcs	1
3	深沟球轴承 deep groove ball bearing	6306	个 pcs	1
4	皮带限位轮 Belt limiting wheel	Ø107x25	个 pcs	1
5	皮带限位轮盖 clenbuterol hydrochloride	Ø120x17	个 pcs	1

2.1.2 1000 型皮带托辊组件及明细表 Model 1000 machine Belt idler Components and specification

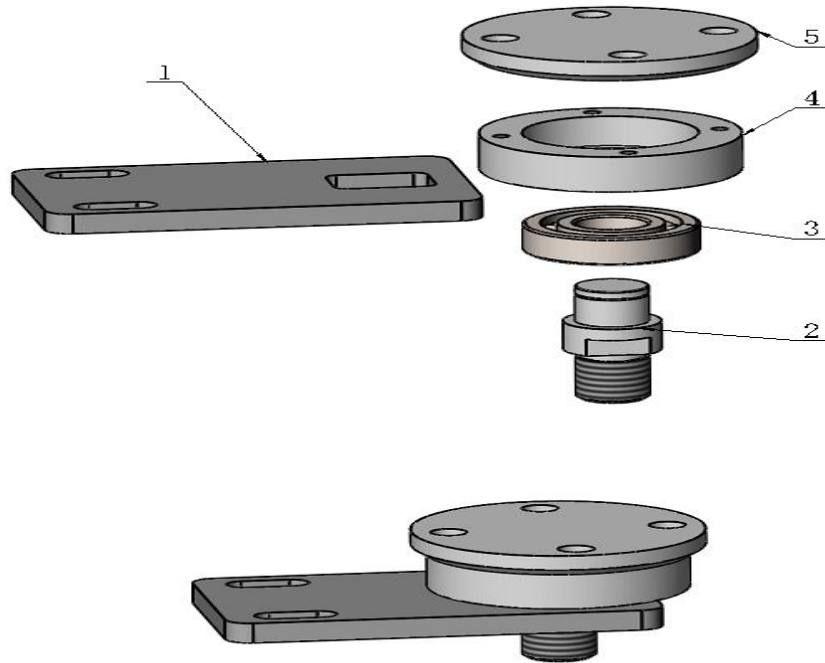

表4 1000 型皮带托辊组件明细表 table4 Model 1000 machine Belt idler Components and specification

序号 NO.	名称 Name	规格型号 Size	单位 Unit	数量 Qty
1	带座轴承 plummer block	UCP208	件 pcs	2
2	1000 机皮带托辊 Model 1000 machine Belt roller	Ø40x1640	条 pcs	1

2.1.3 1000 机被动辊筒组件及明细表 Model 1000 machine Passive roller
Components and specification

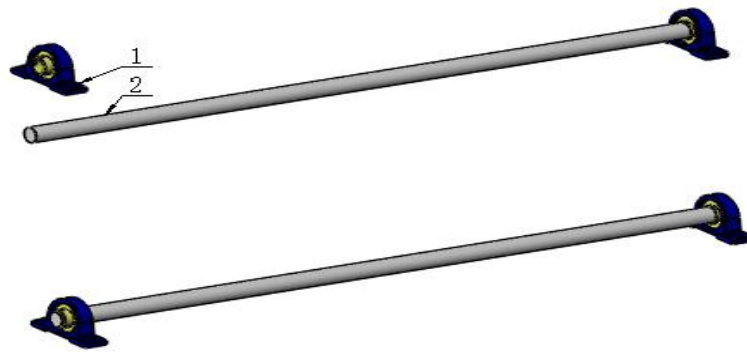

表5 1000 机被动辊筒组件明细表 table5 Model 1000 machine Passive roller Components and specification

序号 NO.	名称 Name	规格型号 Size	单位 Unit	数量 Qty
1	BC 大被动辊支架 (右) BC Large Passive Roll Support (right)	932x200x472	件 pcs	1
2	BC 大被动辊支架 (左) BC Large Passive Roll Support (left)	932x200x472	件 pcs	1
3	1000 机超洁亮被动辊筒 (大) Model 1000 Passive roller (large)	Ø505x1650	件 pcs	1
4	UCT216 滑条 draw slip	530x60x39	件 pcs	4
5	螺杆 screw	M33x500	条 pcs	2
6	带座轴承 plummer block	UCT216	个 pcs	2

2.1.4 1000 机主动辊筒组件及明细表 Model 1000 Machine drive roller
Components and specification

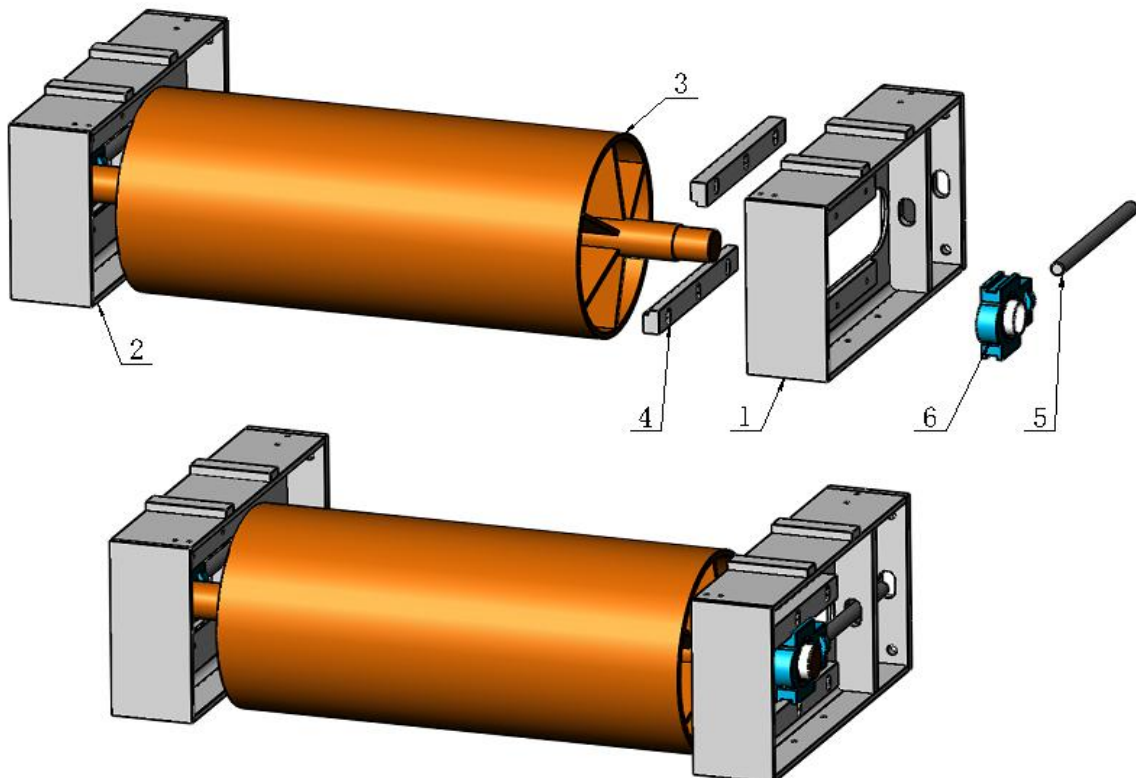

表6 1000 机主动辊筒组件明细表 table6 Model 1000 Machine drive roller Components and specification

序号 NO.	名称 Name	规格型号 Size	单位 Unit	数量 Qty
1	BC 大主动辊支架 (右) Large driving roller support (right)	284x200x450	件 pcs	1
2	BC 大主动辊支架 (左) Large driving roller support (left)	284x200x450	件 pcs	1
3	1000 机超洁亮主动辊筒 (大) Model 1000 Driving roller (large)	Ø505x1725	件 pcs	1
4	BC 机辊筒调整板 Roll adjusting plate	320x175x20	件 pcs	2
5	带座轴承 plummer block	UCP217	个 pcs	2

2.1.5 1000 机过渡辊棒组件 (被动) 及明细表 Model 1000 Machine Transition roller Components (passive) and specification

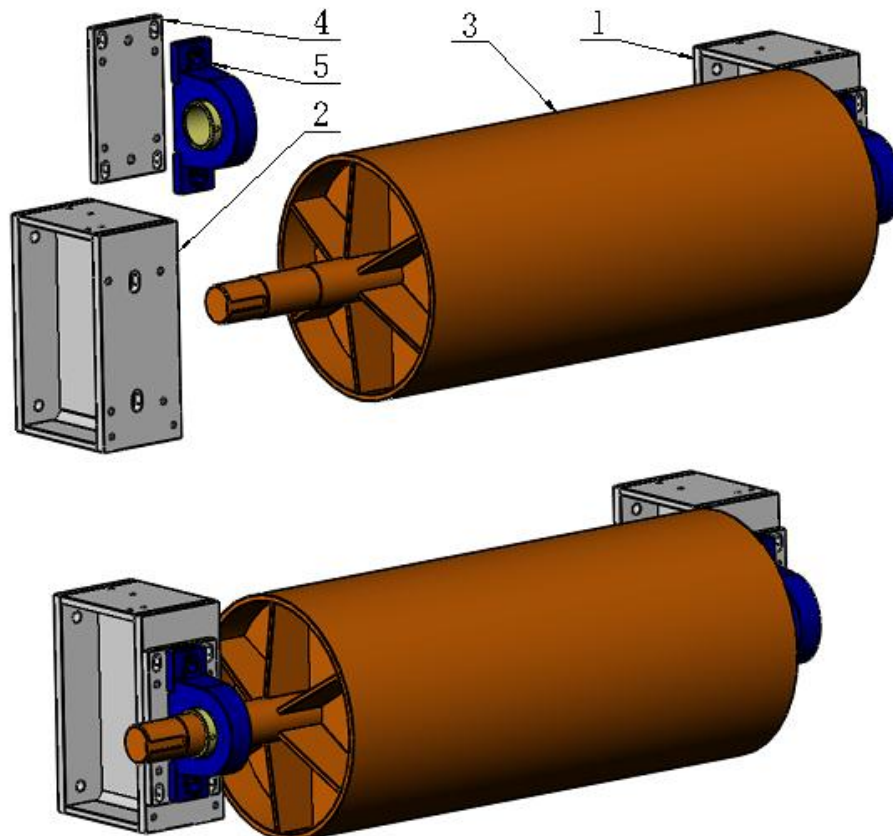

表7 1000 机过渡辊棒组件（被动）明细表 table7 Model 1000 Machine Transition roller
Components(passive) and specification

序号 NO.	名称 Name	规格型号 Size	单位 Unit	数量 Qty
1	过渡辊支架 1（被动左） Transition Roll Support 1 (passive left)	350x70x189	件 set	1
2	过渡辊支架 1（被动右） Transition Roll Support 1 (passive right)	350x70x189	件 set	1
3	过渡辊支架 2（被动左） Transition Roll Support 2 (passive left)	280x80x130	件 set	1
4	过渡辊支架 2（被动右） Transition Roll Support 2 (passive right)	280x80x130	件 set	1
5	1300 过渡辊筒 1300 transition roller	Ø48x1300	条 pcs	2
6	过渡辊轴 Transition roller	Ø25x110	条 pcs	4
7	过渡辊隔套 Transition roller sleeve	Ø27xØ20x20	个 pcs	4
8	深沟球轴承 deep groove ball bearing	6004	个 pcs	8
9	外卡簧 outside spring	Φ 20	个 pcs	4
10	内卡簧 inside spring	Φ 42	个 pcs	4

2.1.6 1000 机过渡辊棒组件（主动）明细表 Model 1000 Machine Transition roller Components (drive) specification

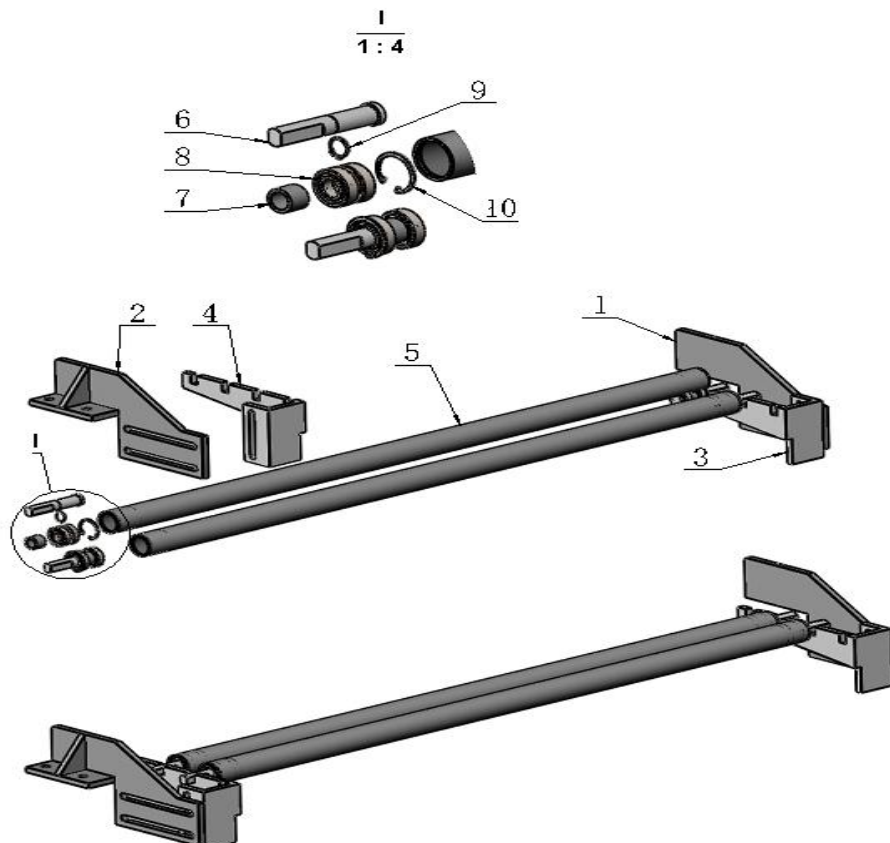

表8 1000 机过渡辊棒组件（主动）明细表 table8 Model 1000 Machine Transition roller Components
(drive) specification

序号 NO.	名称 Name	规格型号 Size	单位 Unit	数量 Qty
1	过渡辊支架 3（被动左） Transition Roll Support 3 (passive left)	450x70x215	件 set	1
2	过渡辊支架 3（被动右） Transition Roll Support 3 (passive right)	450x70x215	件 set	1
3	过渡辊支架 2（被动左） Transition Roll Support 2 (passive left)	280x80x130	件 set	1
4	过渡辊支架 2（被动右） Transition Roll Support 2 (passive right)	280x80x130	件 set	1
5	1300 过渡辊筒 1300 transition roller	Ø48x1300	条 pcs	2
6	过渡辊轴 Transition roller	Ø25x110	条 pcs	4
7	过渡辊隔套 Transition roller sleeve	Ø27xØ20x20	个 pcs	4
8	深沟球轴承 deep groove ball bearing	6004	个 pcs	8
9	外卡簧 outside spring	Φ 20	个 pcs	4
10	内卡簧 inside spring	Φ 42	个 pcs	4

2.1.7 1000 型 8 头超洁亮导蜡槽组件及明细表 Model 1000 8-head Nano
Coating Machine Wax guide tank Components and specification

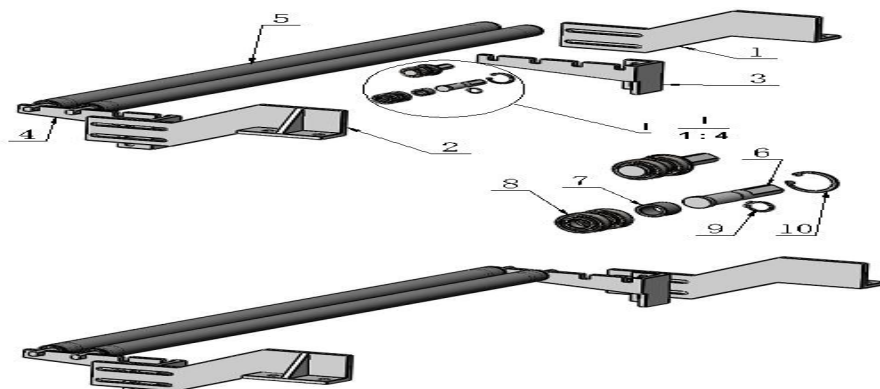

表9 1000 型 8 头超洁亮导蜡槽组件明细表 table9 Model 1000 8-head Nano Coating Machine Wax guide tank Components and specification

序号 NO.	名称 Name	规格型号 Size	单位 Unit	数量 Qty
1	2858 导蜡槽 2858Wax guide groove	2858x125x110+Ø89x500	件 set	4
2	1420 导蜡槽 1420 wax guide groove	1420x125x110	件 set	4
3	2600 导蜡槽 2600 wax guide groove	2600x125x110+两件Ø89x500	件 set	2
4	水槽封板 Water tank sealing plate	280x80x130	件 set	4

2.1.8 超洁亮主传动组件及明细表 Nano coating machine Main drive components and specification

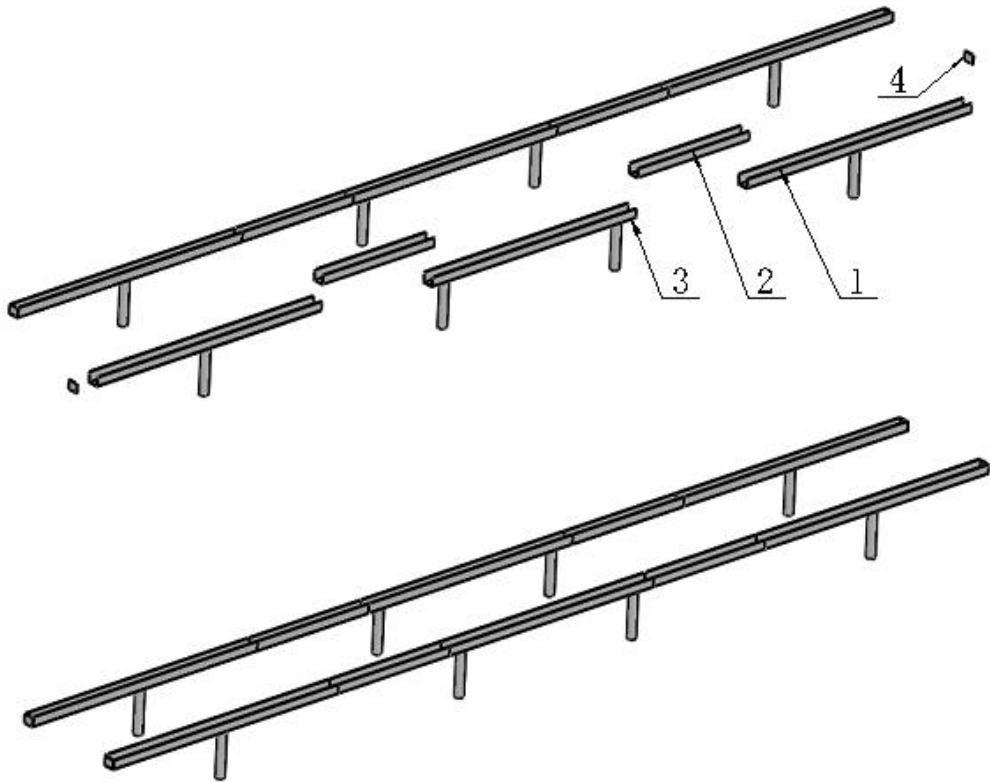

表10 被动调宽座组件明细表 table10 Nano coating machine Main drive components and specification

序号 NO.	名称 Name	规格型号 Size	单位 Unit	数量 Qty
1	超洁亮主传动 F127 机架 Nano coating machine Main drive F127 frame	600x460x243	件 set	1
2	主传动 F127 机架垫板 Main drive F127 frame backing plate	460x150x20	件 set	2
3	主传动减速机 Main drive reducer	F127-Y11-4P-141.2-M6-90°	套 pcs	1
4	超洁亮联轴器 Nano coating machine coupler	Ø110-Ø80	套 pcs	1

2.2 1000 型龙门架组件及明细表 Model 1000 machine portal frame components and specifications

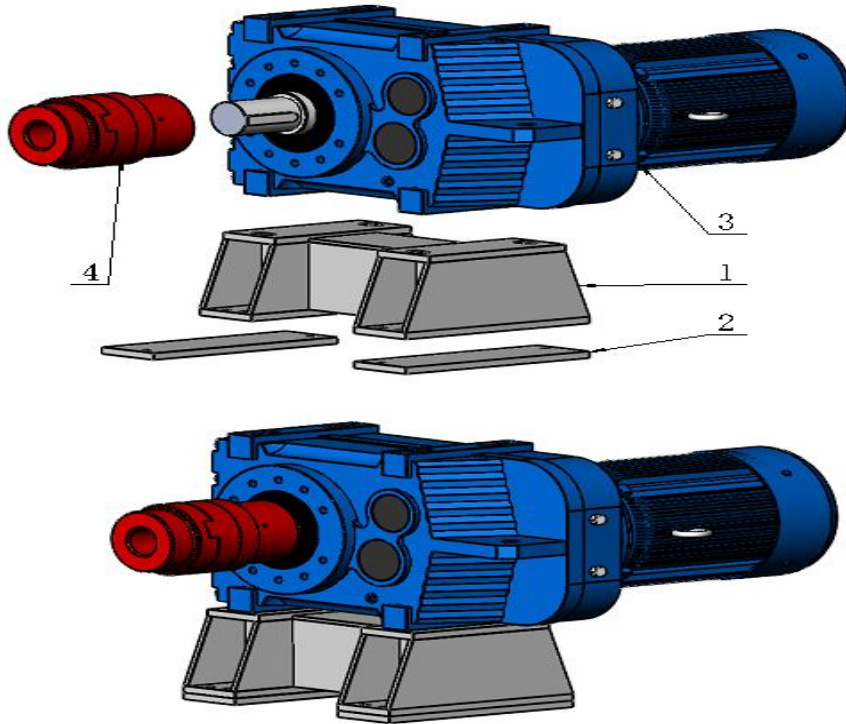

表11 1000 型龙门架组件明细表 table11 Model 1000 portal frame components and specifications

序号 NO.	名称 Name	规格型号 Size	单位 Unit	数量 Qty
1	1000 型龙门架 Model 1000 portal frame	1000 型 Model 1000	件 set	1
2	主轴升降组件 Spindle lifting assembly	988 款	套 pcs	1
3	升降气缸组件 Lifting cylinder assembly	SC100x80 款	套 pcs	2
4	减速机组件 Reducer unit	RV90-15-100B5-4KW	套 pcs	1

5	聚电箱组件 Polymer box assembly		套 pcs	1
6	小磨头组件 Small polishing head assembly	3KW	套 pcs	6
7	1000 型升降限位组件 Model 1000 Lifting limit assembly	1000 型 Model 1000	套 pcs	1
8	气缸顶板 Cylinder top plate	680x290x180	件 set	1
9	磨头多沟带 polishing head multi groove belt	16 沟, L1250	条 pcs	1
10	主轴皮带轮 Main shaft pulley	16 楔, $\varnothing 160 \times \varnothing 70 \times 82$	个 pcs	1
11	1000 型公转盘 Model 1000 (3KW) Revolution disk (3KW)	$\varnothing 1150 \times 20$	件 set	1

2.2.1 主轴升降组件及明细表 Spindle lifting components and specification

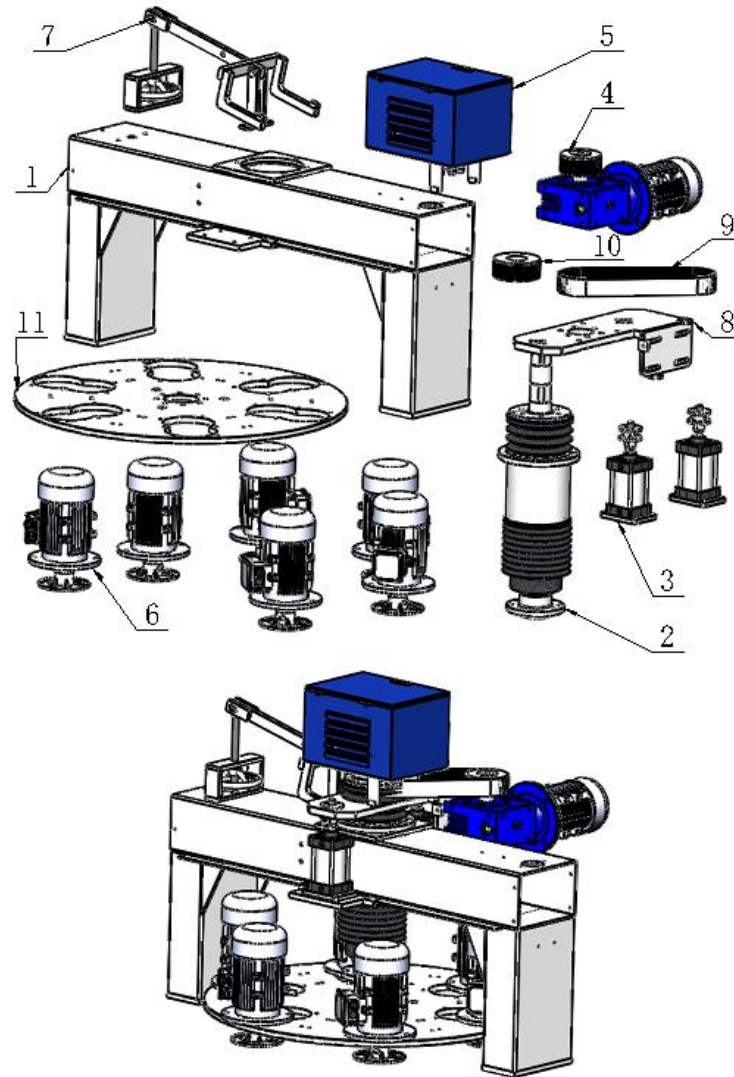

表12 主轴升降组件明细表 table12 Spindle lifting components and specification

序号 NO.	名称 Name	规格型号 Size	单位 Unit	数量 Qty
1	固定筒 Fixed tube	Ø280x235	件 set	1
2	磨头主轴 polishing head spindle	Ø81x988	条 pcs	1
3	滑套 sliding sleeve	Ø156xØ144x600	件 set	1
4	角接触球轴承 angular contact ball bearing	S7215	个 pcs	2
5	轴承上压盖 Bearing upper gland	Ø212xØ76x22	个 pcs	1
6	轴承下压盖 Bearing lower gland	Ø158xØ76x16	个 pcs	1
7	骨架油封 framework oil seal	100X75X10	个 pcs	2
8	转盘连接法兰 Rotary flange connection	Ø200xØ65x70	个 pcs	1
9	主轴压盖 ainshaft gland	Ø100xØ25x10	个 pcs	1
10	防尘罩 2 Dust Cover 2	Ø230xØ170x11 格	个 pcs	1
11	防尘罩 1 Dust Cover 1	Ø230xØ170x6 格	个 pcs	1
12	压板 pressing plate	Ø215xØ185x2, 1/3	件 set	9

2.2.2 升降气缸组件及明细表 Lifting cylinder components and specification

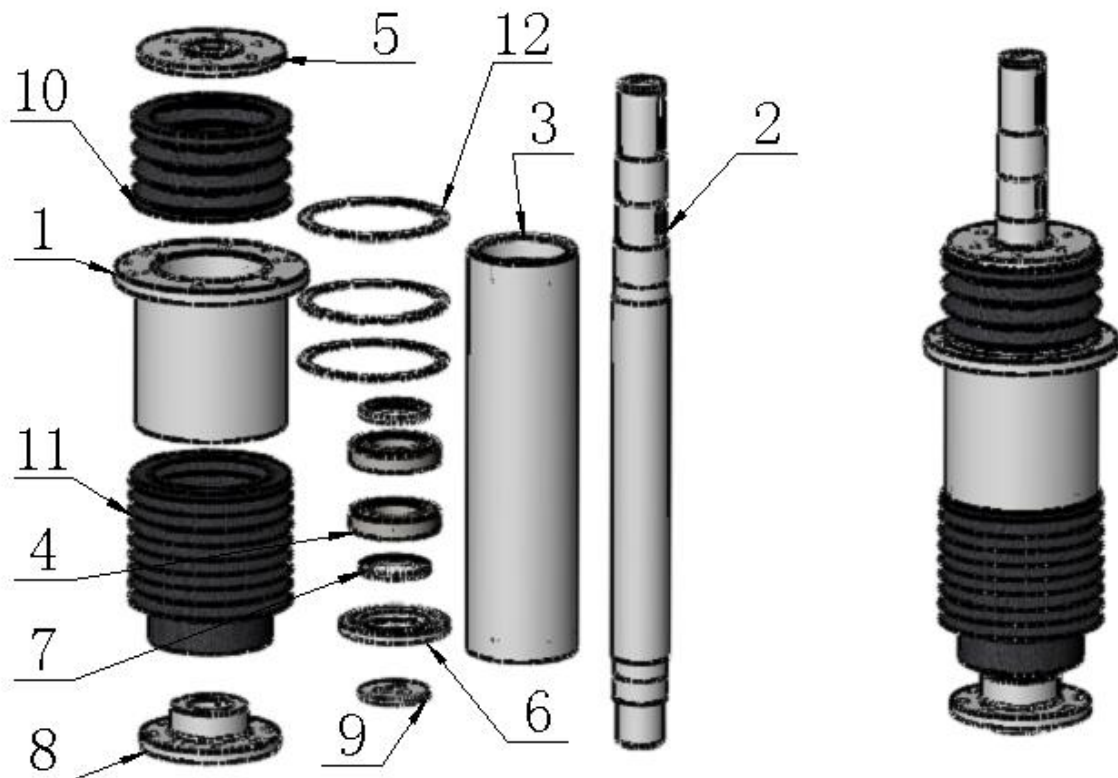

表13 升降气缸组件明细表 table13 Lifting cylinder components and specification

序号 NO.	名称 Name	规格型号 Size	单位 Unit	数量 Qty
1	气缸 air cylinder	SC100x80	个 pcs	1
2	气缸法兰板 Cylinder flange plate	SC100FA	件 set	1
3	连接轴 connecting shaft	Ø35x85	条 pcs	1
4	关节轴承 knuckle bearing	GE30ES-2RS	个 pcs	1
5	下压盖 Lower gland	Ø77xØ39x12	个 pcs	1
6	上压盖 Upper gland	Ø77xØ39x12	个 pcs	1

2.2.3 减速机组件及明细表 Reducer components and specification

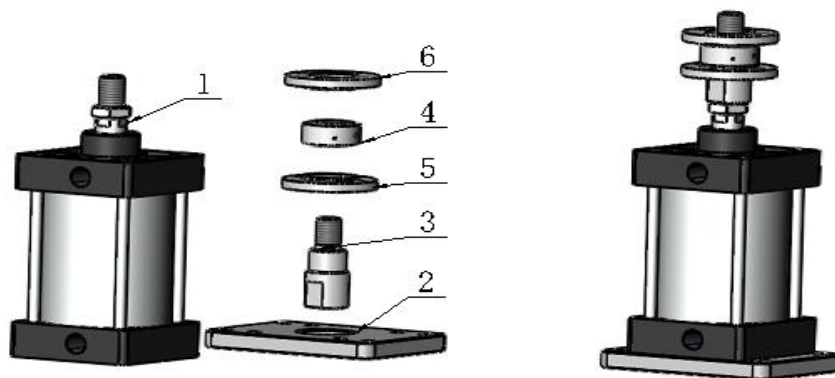

表14 减速机组件明细表 table14 Reducer components and specification

序号 NO.	名称 Name	规格型号 Size	单位 Unit	数量 Qty
1	RV 方箱 RV square box	RV90-15-100B5	台 pcs	1
2	大转盘铝壳电机 Large rotary plate aluminum motor	4KW	台 pcs	1
3	磨头 RV90 方箱轴 (16 楔带轮) polishing head RV90 square box shaft (16 wedgie wheel)	Ø50X248	条 pcs	1
4	电机皮带轮 Motor pulley	16 楔, Ø140x82	个 pcs	1
5	皮带轮压盖 Belt pulley gland	Ø68xØ12x4	个 pcs	1

2.2.4 聚电箱组件及明细表 Polyelectric box components and specification

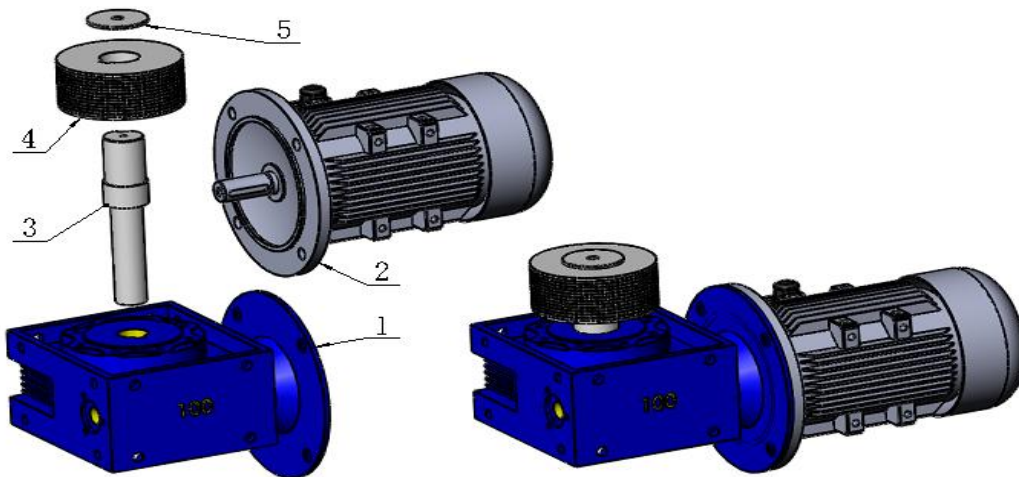

表15 聚电箱组件明细表 table15 Polyelectric box components and specification

序号 NO.	名称 Name	规格型号 Size	单位 Unit	数量 Qty
1	聚电环防护罩 Polyelectric ring protective cover	400X300X260	件 set	1
2	绝缘垫板 insulating padding plate	350X240X15	件 set	1
3	聚电环 Polyelectric ring	46*87*100-3/三件套	套 pcs	1
4	聚电箱支撑杆 Polyelectric box support rod	Ø40X114	条 pcs	3

2.2.5 小磨头组件及明细表 Small polishing head components and specification

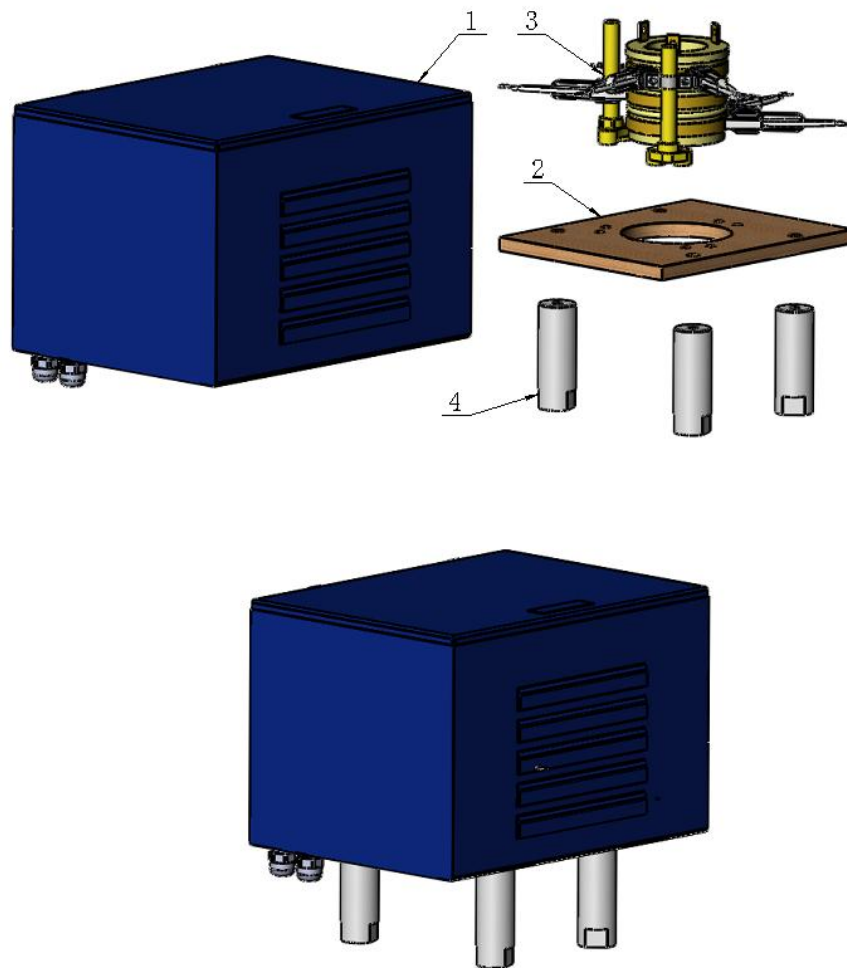

表16 小磨头组件明细表 table16 Small polishing head components and specification

序号 NO.	名称 Name	规格型号 Size	单位 Unit	数量 Qty
1	小磨头铝壳电机 Small polishing head aluminum shell motor	3KW	台 pcs	1
2	圆螺母 round nut	M48x1.5	个 pcs	2
3	调节轴 Shaft of adjustment	Ø52X63	条 pcs	1
4	垫块 53Pad block 53	Ø53xØ11x5	个 pcs	1
5	抛光盘 polishing disk	Ø180X48	个 pcs	1

2.2.6 1000 型升降限位组件及明细表 Model 1000 machine Lifting limit components and specification

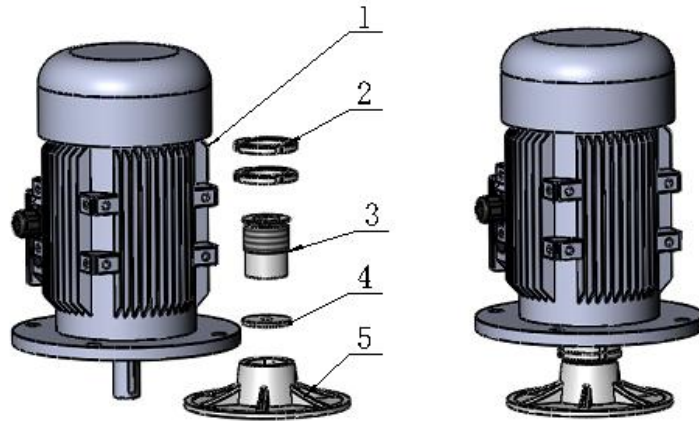

表17 1000 型升降限位组件明细表 table17 Model 1000 machine Lifting limit components and specification

序号 NO.	名称 Name	规格型号 Size	单位 Unit	数量 Qty
1	限位杆支架 Limit rod support	130x40x210	件 set	1
2	1000 机限位杆 Model 1000 Limited rod	690 长	件 set	1
3	限位杆调节架 Limit rod adjustment frame	230x60x124	件 set	1
4	销轴 hinge pin	Ø16	条 pcs	2
5	限位螺杆 Limit screw	Ø28x300	支 pcs	1
6	限位调节手轮 Limit adjustment handwheel	M20 牙孔, 8 寸手轮	个 pcs	1
7	推力球轴承 t hrust ball bearing	51104	个 pcs	1

2.3 1000 型 8 头超洁亮钣金组件及明细表 Model 1000 8-head Nano Coating Machine Sheet metal components and specification

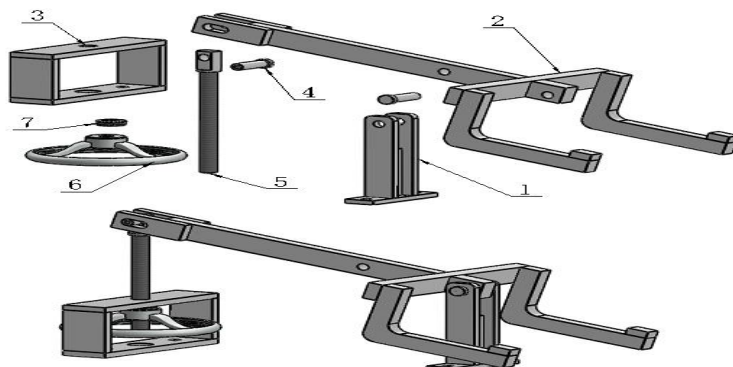

表18 1000 型 8 头超洁亮钣金组件明细表 table18 Model 1000 8-head Nano Coating Machine Sheet
 metal components and specification

序号 NO.	名称 Name	规格型号 Size	单位 Unit	数量 Qty
1	1000 机左侧底梁 Model 1000 Left bottom beam	63x40x6 角铁, 2675 长	件 set	2
2	1000 机中间底梁 Model 1000 Middle bottom beam	63x40x6 角铁, 2560 长	件 set	4
3	1000 机右侧底梁 Model 1000 Right bottom beam	63x40x6 角铁, 2675 长	件 set	2
4	1000 机前侧门组件 Model 1000 Front side door assembly	1000 机 Model 1000	套 pcs	2
5	1000 机前门组件 Model 1000 Front door assembly	1000 机 Model 1000	套 pcs	7
6	1000 机后侧门组件 Model 1000 Rear side door assembly	1000 机 Model 1000	套 pcs	2
7	1000 机后门组件 Model 1000 Back door assembly	1000 机 Model 1000	套 pcs	7
8	1000 机侧罩 Model 1000 Side cover	1738x967x200	件 set	2
9	1000 机两端上封板 Model 1000 Both ends of the sealing plate	1600x600x50	件 set	2
10	1000 机中间上封板 Model 1000 Middle upper seal plate	1600x970x200	件 set	7
11	1000 型 8 头超洁亮面板架组件 Model 1000 8-head Nano Coating Machine Panel rack assembly	1000 型 8 头 Model 1000 8-head	套 pcs	1
12	1000 型 8 头超洁亮挡板组件 Model 1000 8-head Nano Coating Machine Baffle assembly	1000 型 8 头 Model 1000 8-head	套 pcs	1
13	1000 型 8 头线槽组件 (右线) Model 1000 8-head Nano Coating Machine Grooving assembly (right line)	1000 型 8 头 Model 1000 8-head	套 pcs	1

2.3.1 1000 机前侧门组件及明细表 Model 1000 machine Front side door components and specification

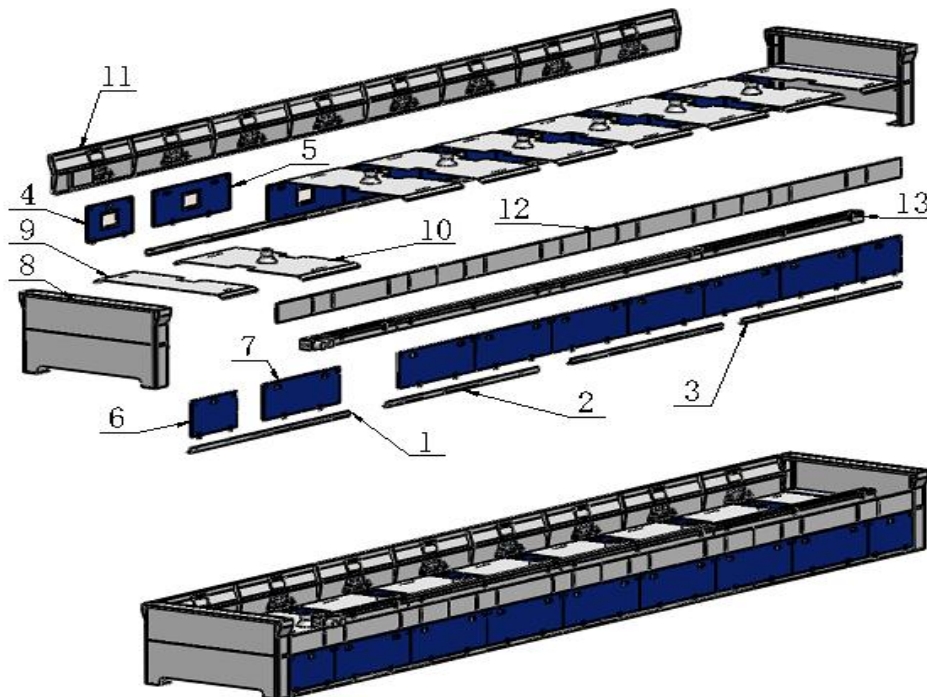

表19 1000 机前侧门组件明细表 table19 Model 1200 machine Front side door components and specification

序号 NO.	名称 Name	规格型号 Size	单位 Unit	数量 Qty
1	1000 机前侧门 Model 1000 Front side door	752x440x22	件 set	1
2	60 铝方合页 60 aluminum square hinge	60x60	件 set	2
3	U 型包边条 U-shaped wrapping strips	10x6x2, 770 长	条 pcs	1
4	有机玻璃 300x210 Plexiglass 300x210	300x210x5	件 set	1
5	有机玻璃压板 300 Plexiglass platen 300	300x20x2	件 set	2
6	隐形拉手 Invisible handle	109x41, M4, 牙距 96	件 set	1

2.3.2 1000 机前门组件及明细表 Model 1000 machine Front door components and specification

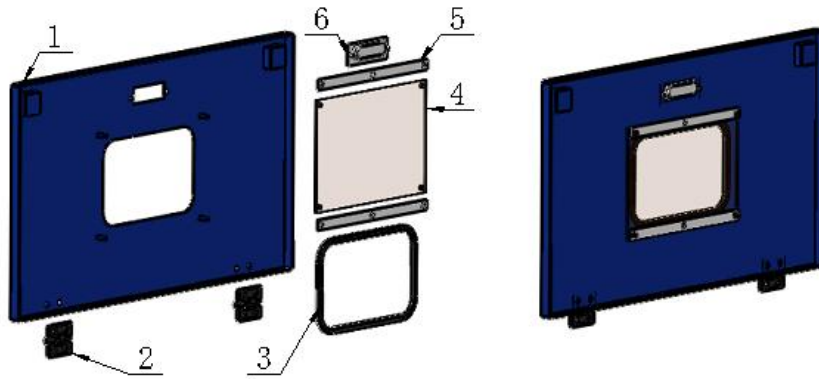

表20 1000 机前门组件明细表 table20 Model 1000 machine Front door components and specification

序号 NO.	名称 Name	规格型号 Size	单位 Unit	数量 Qty
1	1000 机前门 Model 1000 front door	1276x440x22	件 set	1
2	60 铝方合页 60 aluminum square hinge	60x60	件 set	2
3	U 型包边条 U-shaped wrapping strips	10x6x2, 770 长	条 pcs	1
4	有机玻璃 300x210 Plexiglass 300x210	300x210x5	件 set	1
5	有机玻璃压板 300 Plexiglass platen 300	300x20x2	件 set	2
6	隐形拉手 Invisible handle	109x41, M4, 牙距 96	件 set	2

2.3.3 1000 机后侧门组件及明细表 Model 1000 machine Rear side door components and specification

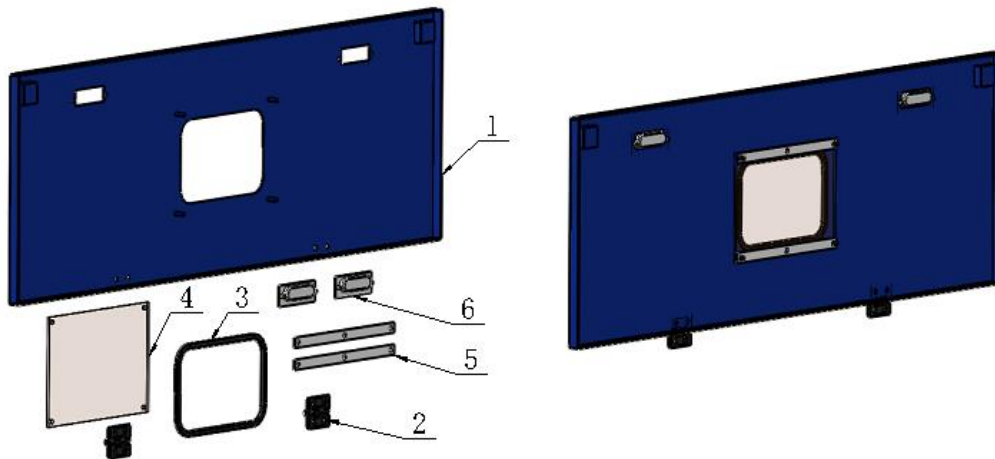

表21 1000 机后侧门组件明细表 table21 Model 1000 machine Rear side door components and specification

序号 NO.	名称 Name	规格型号 Size	单位 Unit	数量 Qty
1	1000 机后侧门 Model 1000 Rear side door	752x440x22	件 set	1
2	60 铝方合页 60 aluminum square hinge	60x60	件 set	2
3	隐形拉手 Invisible handle	109x41, M4, 牙距 96	件 set	1

2.3.4 1000 机后门组件及明细表 Model 1000 machine Backdoor components and specification

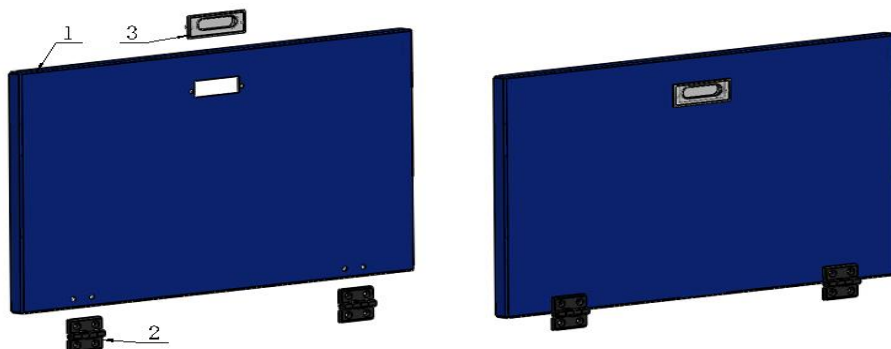

表22 1000 机后门组件明细表 table22 Model 1000 machine Backdoor components and specification

序号 NO.	名称 Name	规格型号 Size	单位 Unit	数量 Qty
1	1000 机后门 Model 1000 back door	1276x440x22	件 set	1
2	60 铝方合页 60 aluminum square hinge	60x60	件 set	2
3	隐形拉手 Invisible handle	109x41, M4, 牙距 96	件 set	2

2.3.5 1000 型 8 头超洁亮面板架组件及明细表 Model 1000 8-head Nano Coating Machine Panel rack components and specification

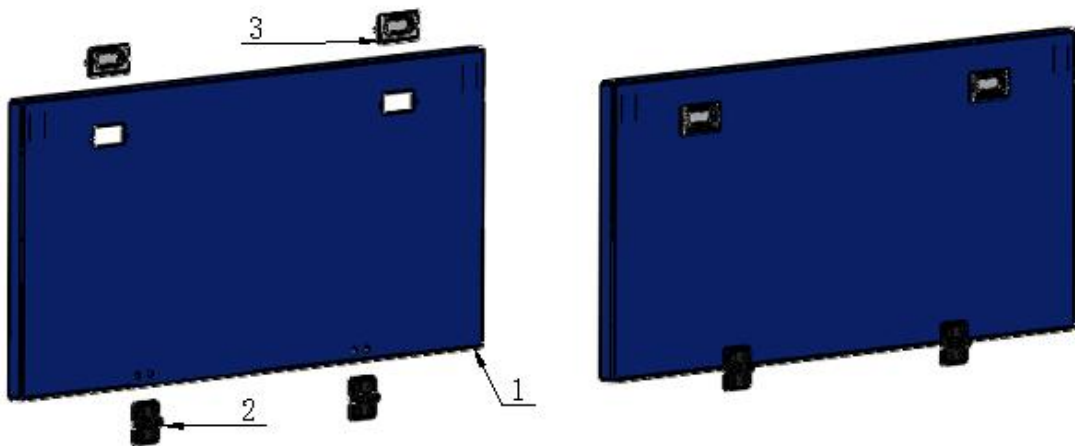

表23 1000 型 8 头超洁亮面板架组件明细表 table23 Model 1000 8-head Nano Coating Machine Panel

rack components and specification

序号 NO.	名称 Name	规格型号 Size	单位 Unit	数量 Qty
1	1000 机被动侧面板架 (右线) Model 1000 Panel Rack Assembly and Specification Passive Side panel rack (right line)	2676x478x108	件 set	1
2	1000 机中间面板架 Model 1000 Middle panel rack	2560x478x108	件 set	2
3	1000 机主动侧面板架 (右线) Model 1000 Active side shelving (right line)	2676x478x108	件 set	1
4	U 型包边条 U-shaped wrapping strips	10x6x2, 770 长	条 pcs	8
5	插板导向板垫板 Insert plate guide plate spacer plate	280x20x3	件 set	16
6	插板导向板 Insert guide plate	280x35x2	件 set	16
7	插板 spile	240x125x2	件 set	8
8	星形把手	M8×32	个 pcs	8

	star grip knob			
9	打蜡机磨头面板 Wax machine polishing head panel	300x200x2	件 set	8
10	打蜡机主控制面板 (三菱) Wax machine main control panel (Mitsubishi)	300x200x2	件 set	1
11	连接支架 attachment bracket	50x50x40	件 set	15

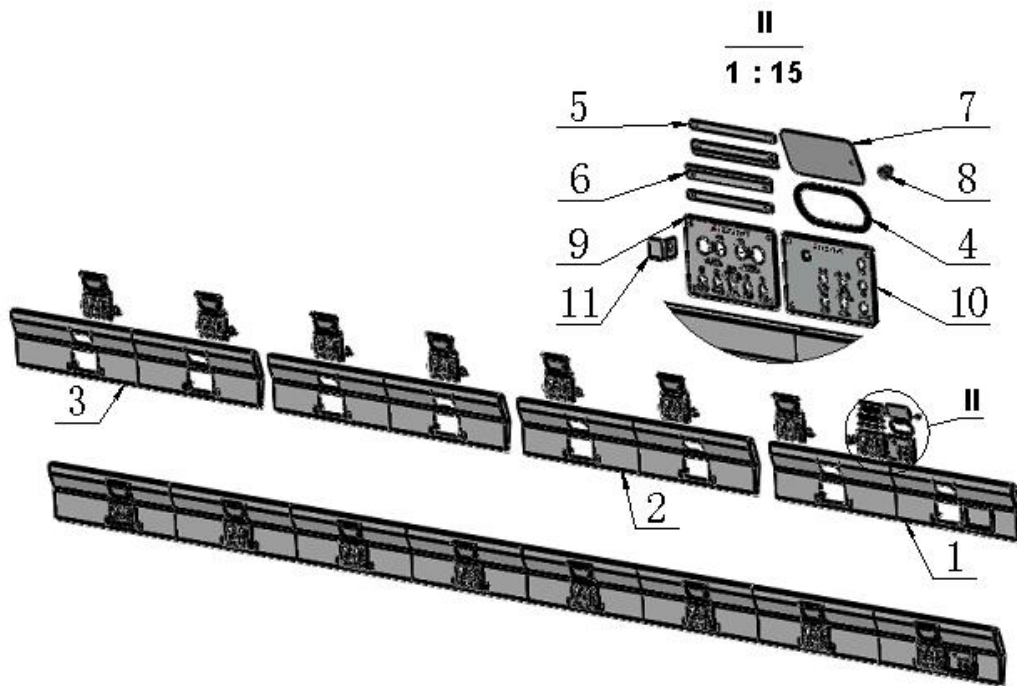
2.3.6 1000 型 8 头超洁亮挡板组件及明细表 Model 1000 8-head Nano Coating Machine Baffle components and specification



表24 1000 型 8 头超洁亮挡板组件明细表 table24 Model 1000 8-head Nano Coating Machine Baffle components and specification

序号 NO.	名称 Name	规格型号 Size	单位 Unit	数量 Qty
1	1000 机侧挡板 Model 1000 side baffle	2676x240x25	件 set	2
2	1000 机中间挡板 Model 1000 Middle baffle	2560x240x25	件 set	2
3	挡板安装架 Baffle mounting frame	63x40x6xL170	件 set	16

2.3.7 1000 型 8 头超洁亮线槽组件 (右线) 及明细表 Model 1000 8-head Nano Coating Machine Slot components (right line) and specification

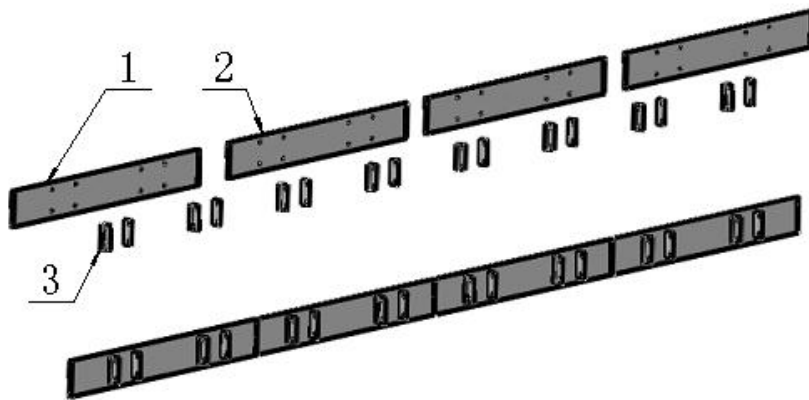

表25 1000 型 8 头超洁亮线槽组件（右线）明细表 table25 Model 1000 8-head Nano Coating Machine

Slot components (right line) and specification

序号 NO.	名称 Name	规格型号 Size	单位 Unit	数量 Qty
1	1000 机线槽 A（右线） Model 1000 Slot A (right line)	2710x140x120	件 set	1
2	线槽 2560 Slot 2560	2560x140x120	件 set	2
3	1000 机线槽 B（右线） Model 1000 Slot B (right line)	1430x237x120	件 set	1
4	1000 机线槽盖 A Model 1200 Slot cover A	2707x85x43	件 set	1
5	线槽盖 2560 Slot cover 2560	2560x85x43	件 set	2
6	1000 机线槽盖 B Model 1000 Slot cover B	1150x85x43	件 set	1
7	线槽 B 盖板 Slot B cover plate	280x100x2	件 set	1
8	60 铝方合页 60 aluminum square hinge		个 pcs	11

2.4 1000 型 8 头超洁亮管道组件及明细表 Model 1000 8-head Nano Coating

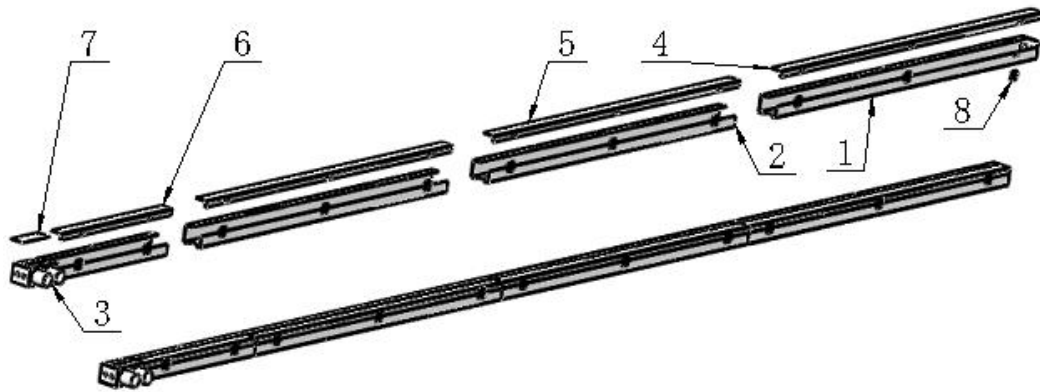
Machine Piping components and specification



表26 1000 型 8 头超洁亮管道组件明细表 table26 Model 1000 8-head Nano Coating Machine Piping components and specification

序号 NO.	名称 Name	规格型号 Size	单位 Unit	数量 Qty
1	1000 型 8 头超洁亮风管组件 Model 1000 8-head Nano Coating Machine flue pipe assembly	1000 型 8 头 Model 1000 8-head	套 pcs	1
2	1000 型 8 头超洁亮总气管组件 Model 1000 8-head Nano Coating Machine Total tracheal assembly	1000 型 8 头 Model 1000 8-head	套 pcs	1
3	1000 型 8 头超洁亮加蜡管道组件 Model 1000 8-head Nano Coating Machine Wax pipe assembly	1000 型 8 头 Model 1000 8-head	套 pcs	1

2.4.1 1000 型 8 头超洁亮风管组件及明细表 Model 1000 8-head Nano Coating Machine flue pipe components and specification

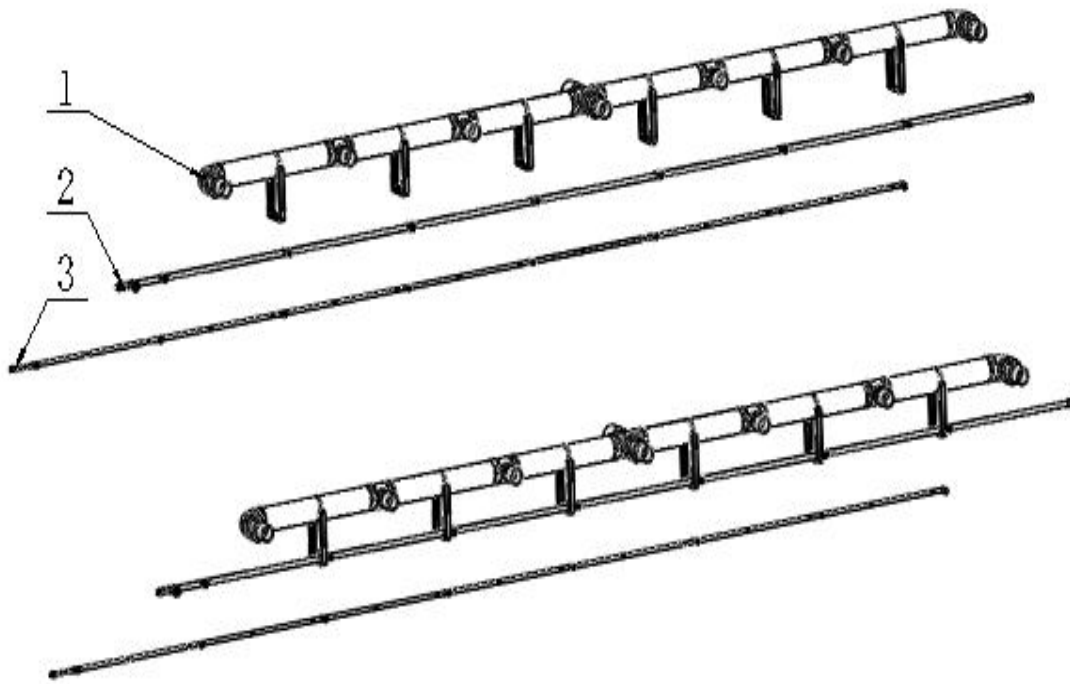

表27 1000 型 8 头超洁亮风管组件明细表 table27 Model 1000 8-head Nano Coating Machine flue pipe components and specification

序号 NO.	名称 Name	规格型号 Size	单位 Unit	数量 Qty
1	PVC160 四通 pvc160cross	内径 4-Ø160	个 pcs	1
2	160 管 1100 pipe	外径Ø160x1100	条 pcs	2
3	PVC 三通 (160 转 110) PVC reducing tee	2-Ø160 内径转Ø110	个 pcs	4
4	160 管 1150 pipe	外径Ø160x1150	条 pcs	4
5	160 管 90 度 160 ELBOW	90° 弯头, 内径Ø160	个 pcs	2
6	160 管 120 pipe	外径Ø160x120	条 pcs	3
7	PVC160 转 110 直通 PVC160 reducer	内径Ø160 转Ø110	个 pcs	3
8	110 风管 150 pipe	外径Ø110x150	条 pcs	7
9	160 管 200 pipe	外径Ø160x200	条 pcs	1
10	风管支架 A flue pipe bracket A	220x50x330	件 set	6
11	管码 pipe clamp	Ø160	件 set	6

2.4.2 1000 型 8 头超洁总气管组件及明细表 Model 1000 8-head Nano Coating Machine Total tracheal components and specification

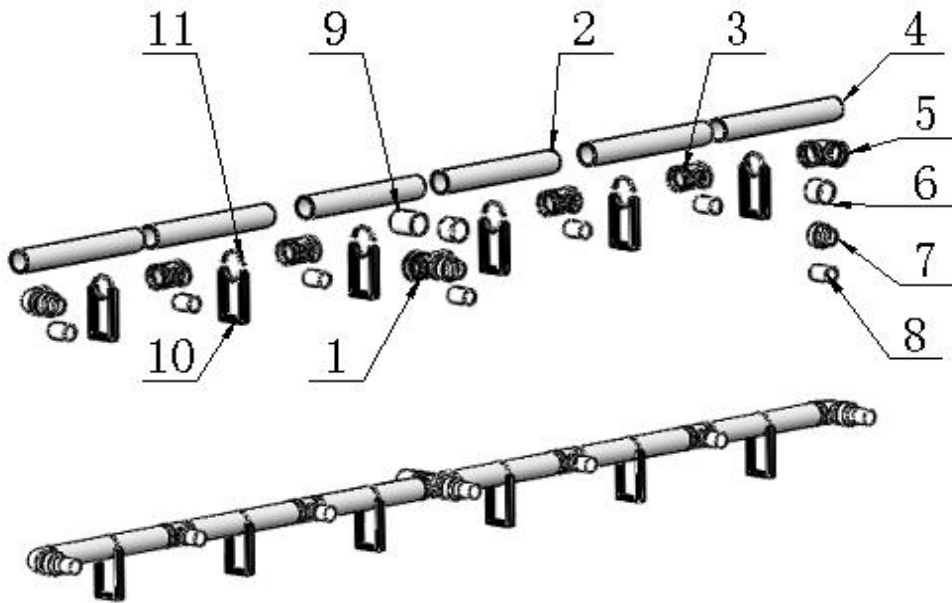

表28 1000 型 8 头超洁亮总气管组件明细表 table28 Model 1000 8-head Nano Coating Machine Total tracheal components and specification

序号 NO.	名称 Name	规格型号 Size	单位 Unit	数量 Qty
1	1 寸管 L1240 pipe	外径032x1240	条 pcs	7
2	1 寸管 L280 pipe	外径032x280	条 pcs	1
3	1 寸管 L80 pipe	外径032x180	条 pcs	1
4	1 寸转 4 分带牙直通 reducer		个 pcs	1
5	1 寸转 6 分带牙直通 reducer		个 pcs	1
6	1 寸转 4 分带牙三通 tee		个 pcs	7
7	闸阀 gate valve	032PPR 截止阀	个 pcs	1
8	气管接头 reducer	PC8-04	个 pcs	8
9	补芯+直快 reducer	6 转 4 分-016	个 pcs	1

2.4.3 1000 型 8 头超洁亮加蜡管道组件及明细表 Model 1000 8-head Nano Coating Machine Waxed pipe components and specification

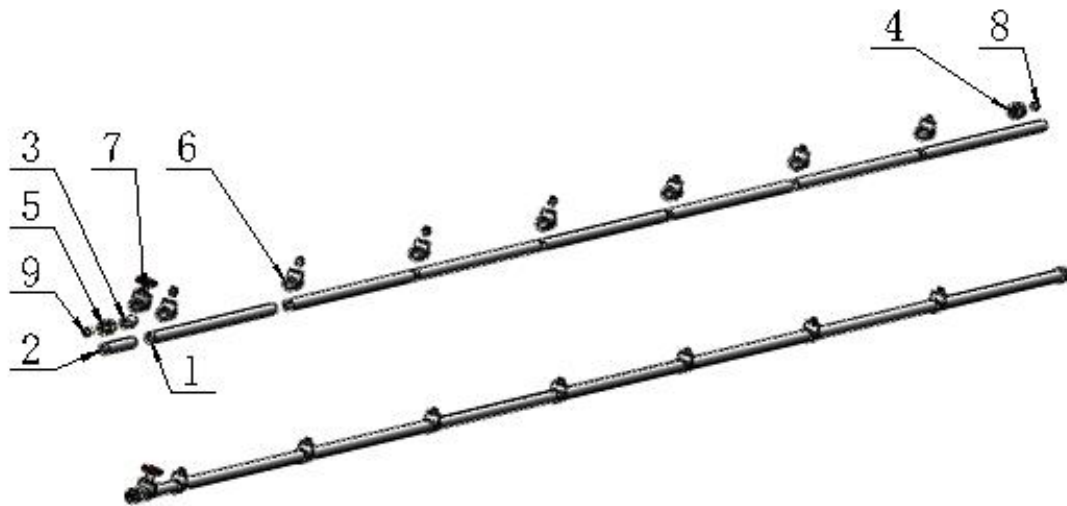
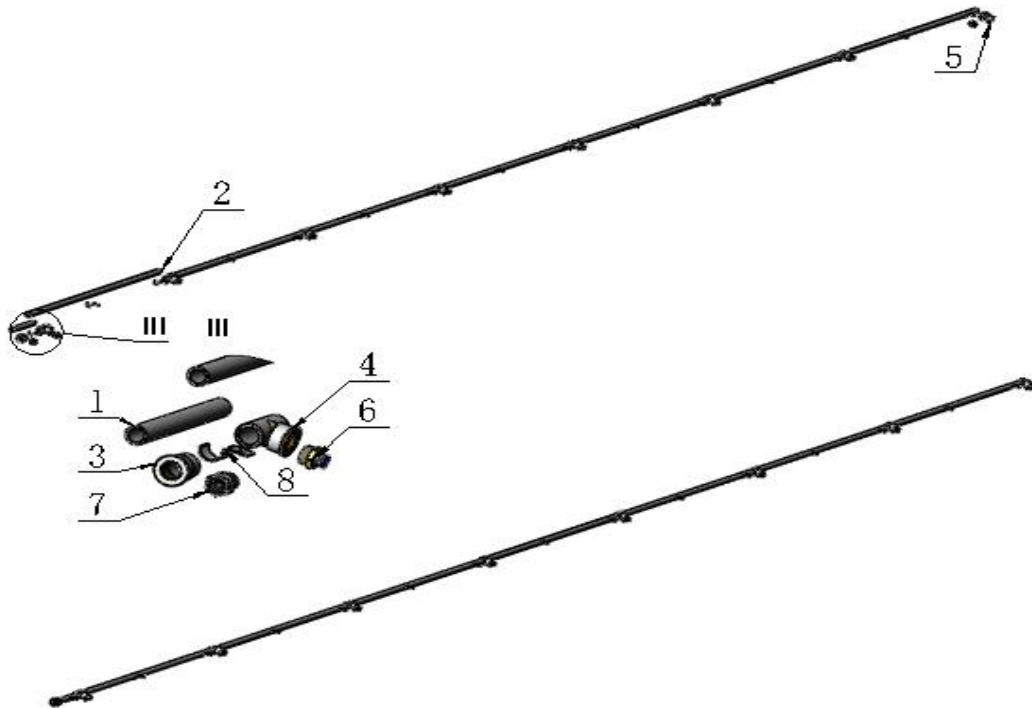

表29 1000 型 8 头超洁亮加蜡管道组件明细表 table29 Model 1000 8-head Nano Coating Machine Waxed pipe components and specification

序号 NO.	名称 Name	规格型号 Size	单位 Unit	数量 Qty
1	4 分 PPL 管 200 pipe	200 长	条 pcs	1
2	4 分 PPL 管 1250 pipe	1250 长	条 pcs	7
3	4 分管 PPL 直通 reducer	Ø20-G1 / 2	个 pcs	1
4	4 分管 PPL 三通 tee	2xØ20-G1 / 2	个 pcs	7
5	4 分管 90° PPL 弯头 elbow	Ø20-G1 / 2	个 pcs	1
6	气管接头 reducer	PC8-04	个 pcs	8
7	直快 reducer	4 分-Ø16	个 pcs	1
8	4 分单边管卡 half coupling		个 pcs	15